

GROUP 12 — TRANSMISSION

GENERAL INFORMATION

Some metric fasteners have been incorporated into the Checker transmission. The following list of changes should help in obtaining the necessary tools for service.

1. Transmission Torque converts to Flywheel mounting bolts.
15MM HEX (10MM threads).
2. Speedometer Driven Gear Housing Retainer Bolt
10MM HEX (6MM thread)

TRANSMISSION CONTROLS

KICK-DOWN SWITCH

The transmission kick-down switch is mounted on the accelerator pedal support reinforcement assembly inside the vehicle, Fig. 2.

Two electrical wires in a connector, one pink and one black, are connected to the switch. The pink wire has continuity when the ignition switch is in "on" position and the black wire has continuity when the kick-down switch is closed. This is achieved when the accelerator pedal is pressed to the floor causing the accelerator pedal lever to make contact with the kick-down switch pin.

REPLACEMENT (FIG. 2)

1. Disconnect wire connector from switch.
2. Remove bolt and remove switch.
3. Reverse removal procedure to install a new switch.
4. Set the switch to the full open position by pushing the switch pin all the way up.

NOTE: The kick-down switch is a self adjusting switch. When the accelerator pedal is pressed to the floor, it will automatically set the switch.

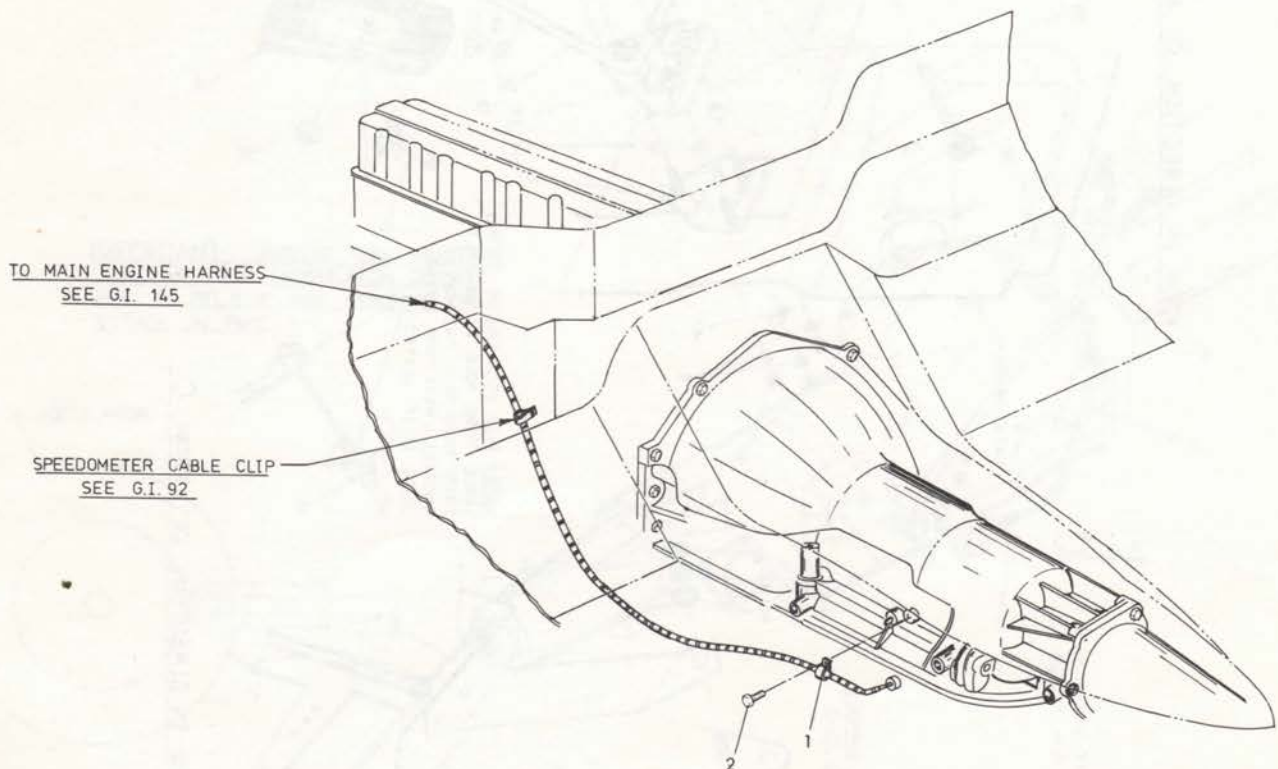

FIGURE 1—Kick-down Switch Wiring.

GROUP 12 — TRANSMISSION

TRANSMISSION CONTROLS - CONT'D.

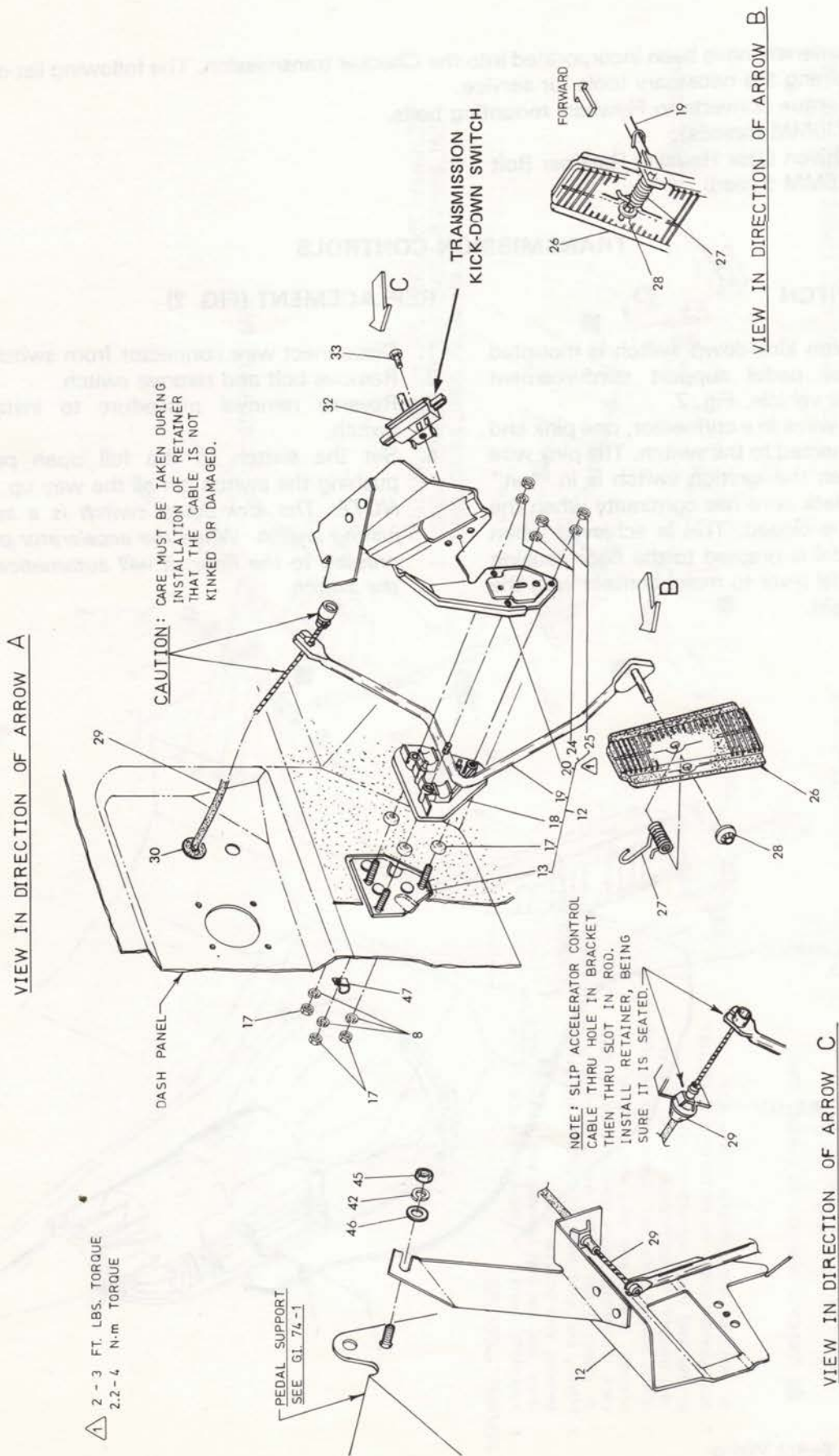

FIGURE 2—Throttle Linkage and Kick-Down Switch Installation - 6 and 8 Cylinder.

GROUP 12 — TRANSMISSION

TRANSMISSION CONTROLS CONT'D.

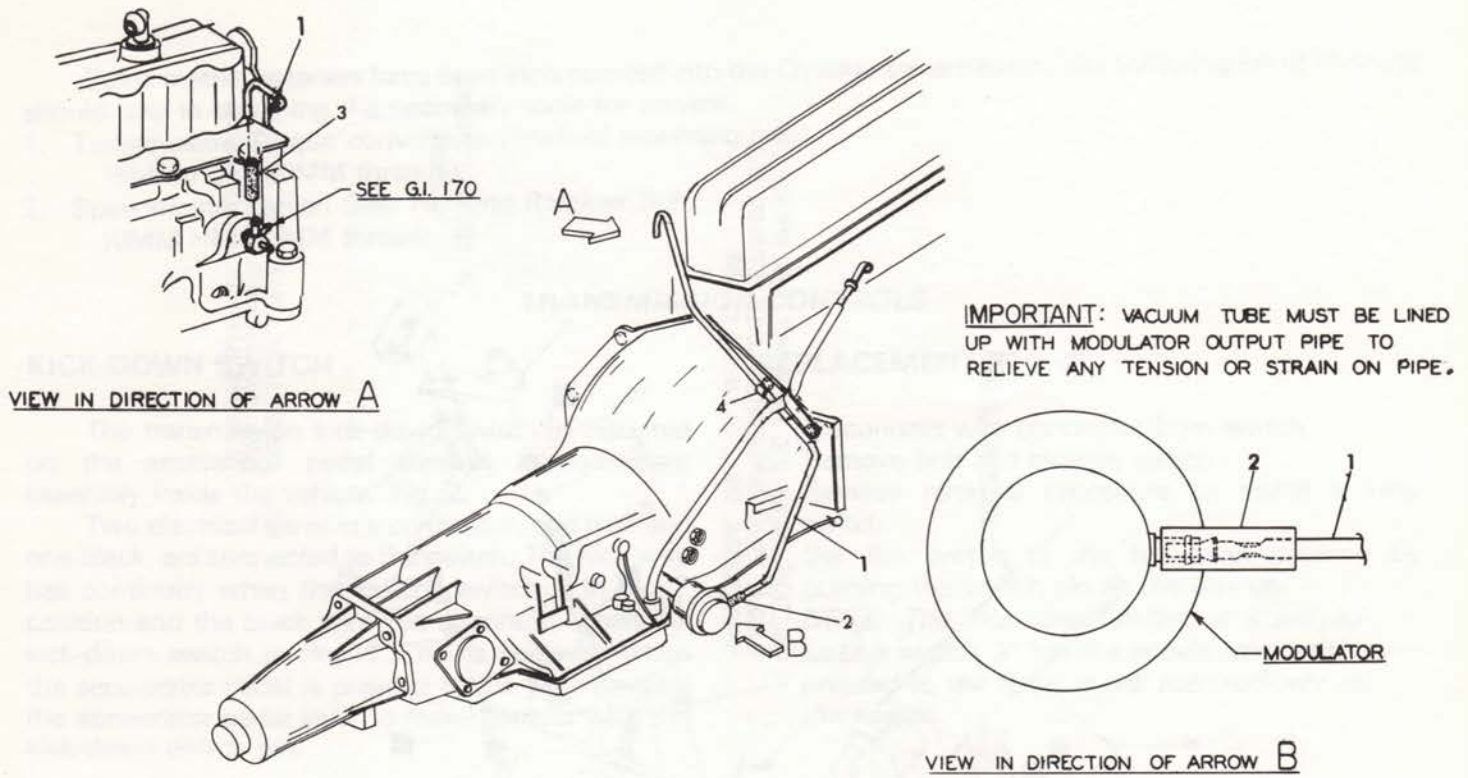

FIGURE 3—Vacuum Controls - 6 Cylinder.

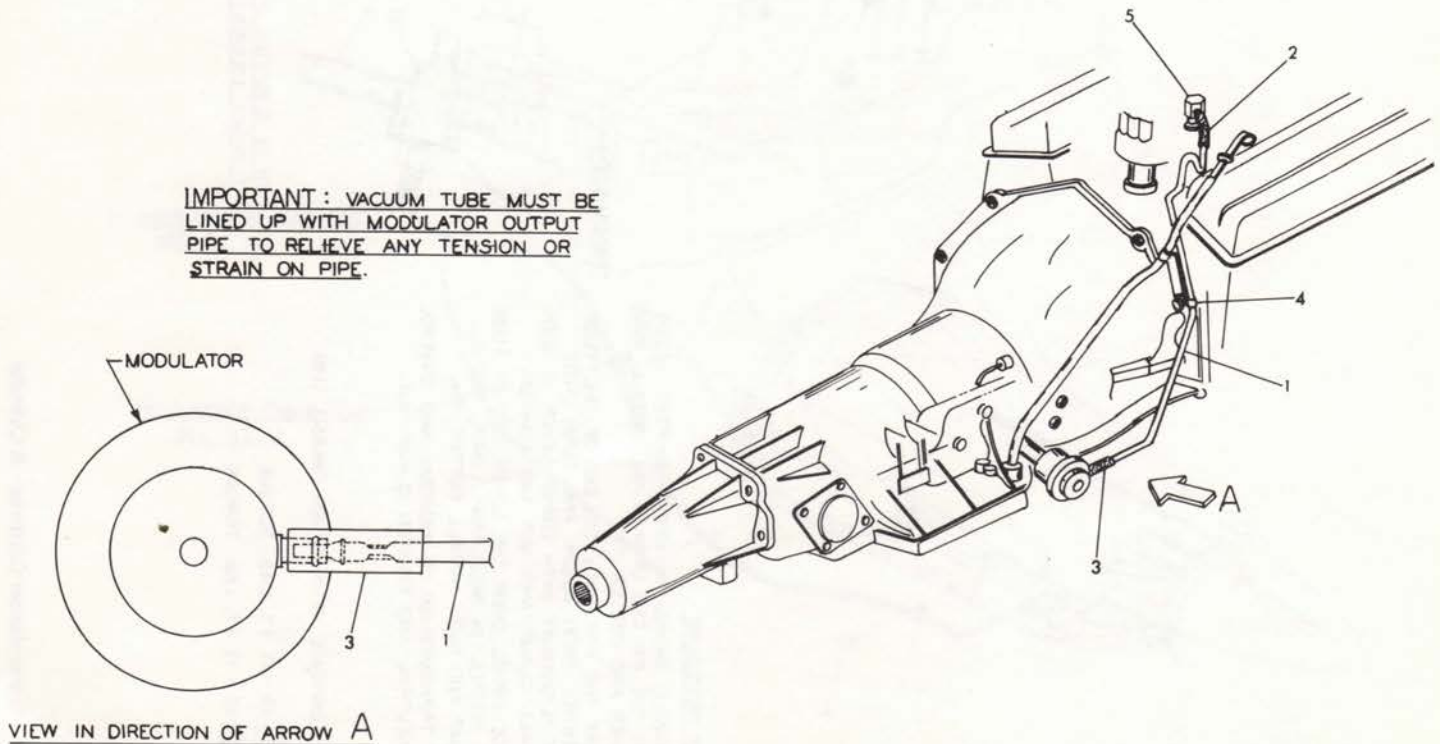
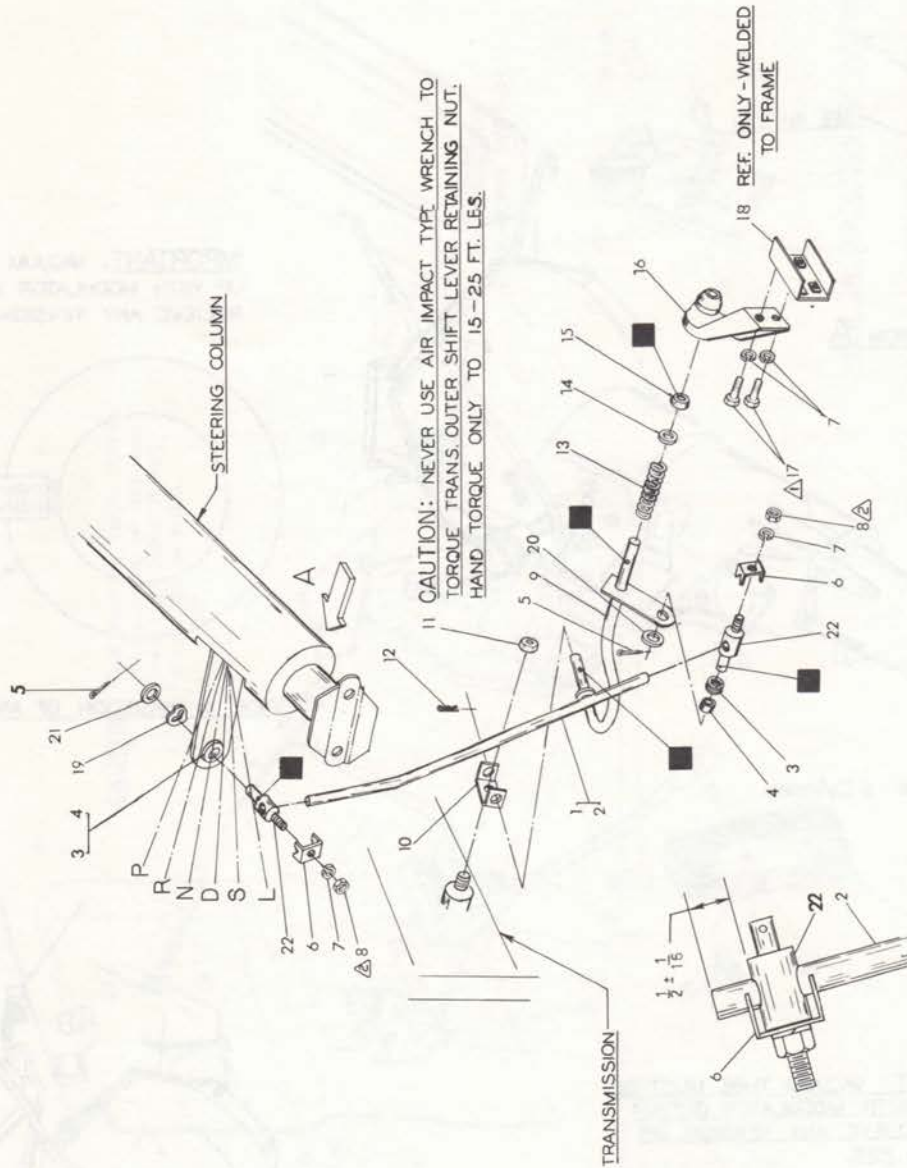

FIGURE 4—Vacuum Controls - 8 Cylinder

GROUP 12 — TRANSMISSION
 TRANSMISSION CONTROLS - CONT'D.



ASSEMBLY PROCEDURE

1. ASSEMBLE SWIVEL IN UPPER SHIFTER LEVER WITH THE PIN END UPWARD AND INSTALL WAVE WASHER AND COTTER PIN.
2. INSERT THE 'FIVE INCH' (5") END OF THE TUBE IN SWIVEL FROM BELOW AND TURN UNTIL FREE ALIGNMENT WITH LOWER LEVER IS SEEN. INSTALL CLAMP AND NUT AND TIGHTEN.
3. PLACE SWIVEL OVER THE LOWER END OF TUBE AND INSTALL IN BELLCRANK LEVER. INSTALL CLAMP AND NUT. INSTALL COTTER PIN.
4. SET TRANSMISSION IN NEUTRAL AND CONTROL IN NEUTRAL AND TIGHTEN CLAMP NUT.

■ LUBRICATE WITH MI-106 CHASSIS LUBE

△ 15 - 17 FT. LBS. TORQUE

△ 13 - 15 FT. LBS. TORQUE

FIGURE 5—Transmission Controls - 6 Cylinder.

GROUP 12 - TRANSMISSION

TRANSMISSION CONTROLS CONT'D.

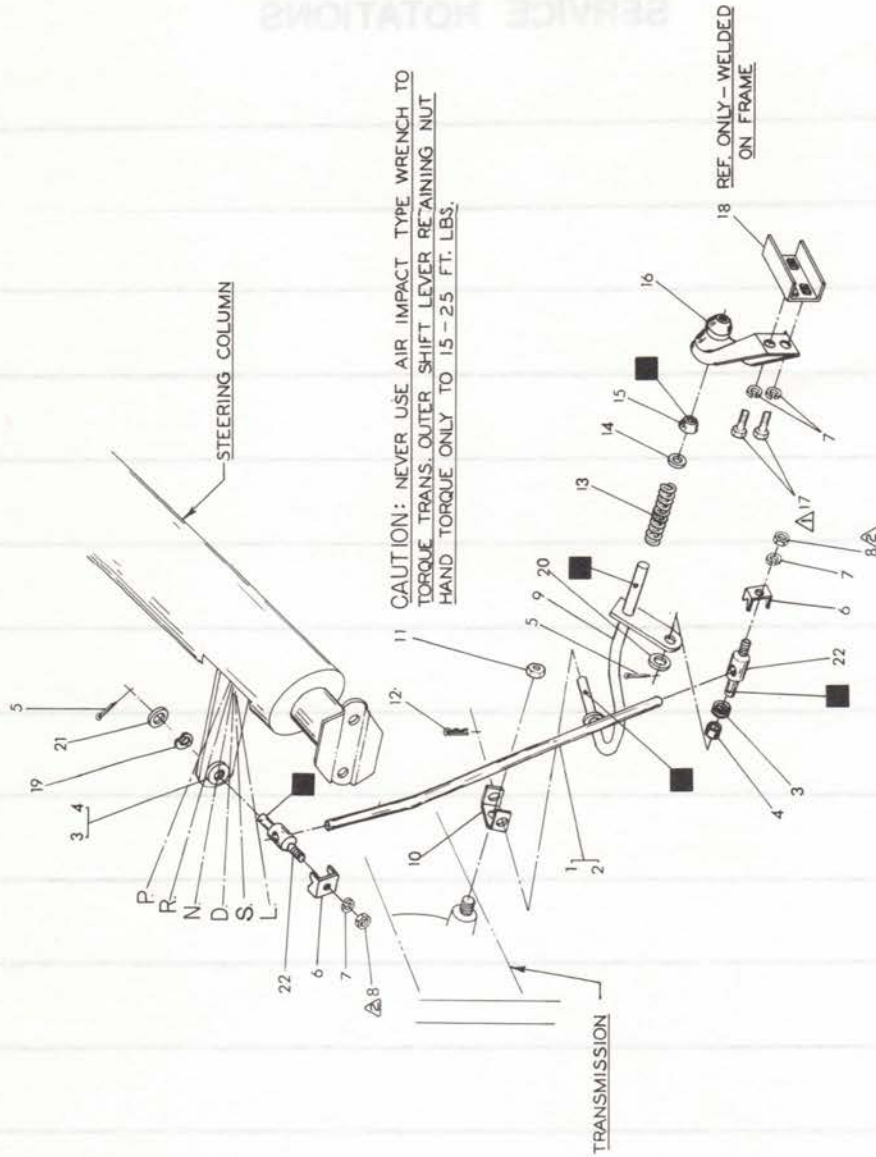

ASSEMBLY PROCEDURE

1. ASSEMBLE SWIVEL IN UPPER SHIFTER LEVER WITH THE PIN END UPWARD AND INSTALL WAVE WASHER AND COTTER PIN.
2. INSERT THE "FIVE INCH" (5") END OF THE TUBE IN SWIVEL FROM BELOW AND TURN UNTIL FREE ALIGNMENT WITH LOWER LEVER IS SEEN. INSTALL CLAMP AND NUT AND TIGHTEN.
3. PLACE SWIVEL OVER THE LOWER END OF TUBE AND INSTALL IN BELLCRANK LEVER. INSTALL CLAMP AND NUT. INSTALL COTTER PIN IN NEUTRAL AND TIGHTEN CLAMP NUT.
4. SET TRANSMISSION IN NEUTRAL AND CONTROL IN NEUTRAL AND TIGHTEN CLAMP NUT.

▲ 15 - 17 FT. LBS. TORQUE

▲ 13 - 15 FT. LBS. TORQUE

■ LUBRICATE WITH MI-106 CHASSIS LUBE

FIGURE 9—Transmission Controls - 8 Cylinder.